

Truck-mounted concrete pump

BSF 16.09 H

Output up to 90 m³/h
Delivery pressure up to 78 bar

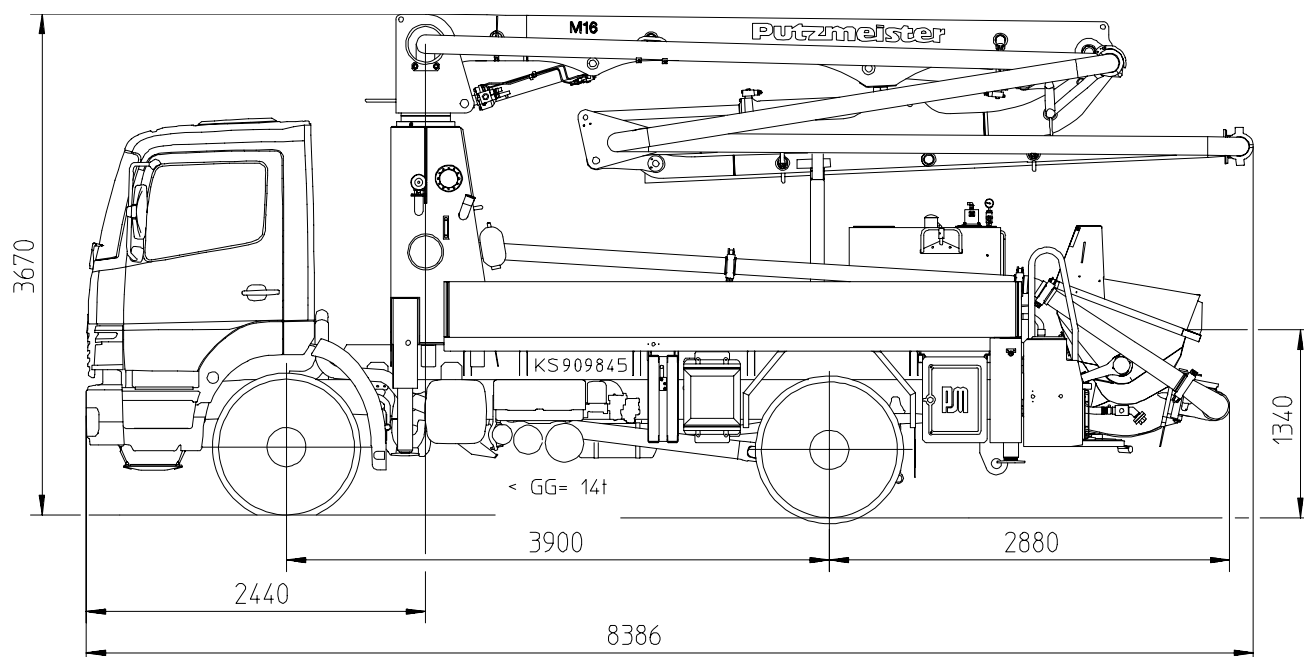
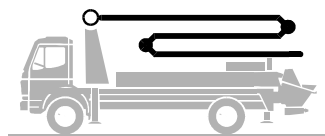

Note: Standard version. Dimensions and weights depend on truck and pump model.
Dimensions in mm, MB-Axor 1523 as example

Technical Data

Boom M 16			
Reach height	m	16.4	
Horizontal reach	gross	m	13.0
	net	m	10.5
Reach depth max.	m	8.1	
Unfolding height	m	4.1	
End hose length	m	3	
Number of arms	3		
Folding system	Z-fold (Z)		
Delivery line	DN 100/4.5		

Pump		BSF	.09 H
Rod side	Output	m ³ /h	-
	Delivery pressure	bar	-
	Strokes	1/min.	26
Piston side	Output	m ³ /h	90
	Delivery pressure	bar	78
	Strokes	1/min.	26
Delivery cylinder		∅ mm	230
Stroke		mm	1400

All data maximum theoretical.

Reach information diagram, Support, Performance diagram

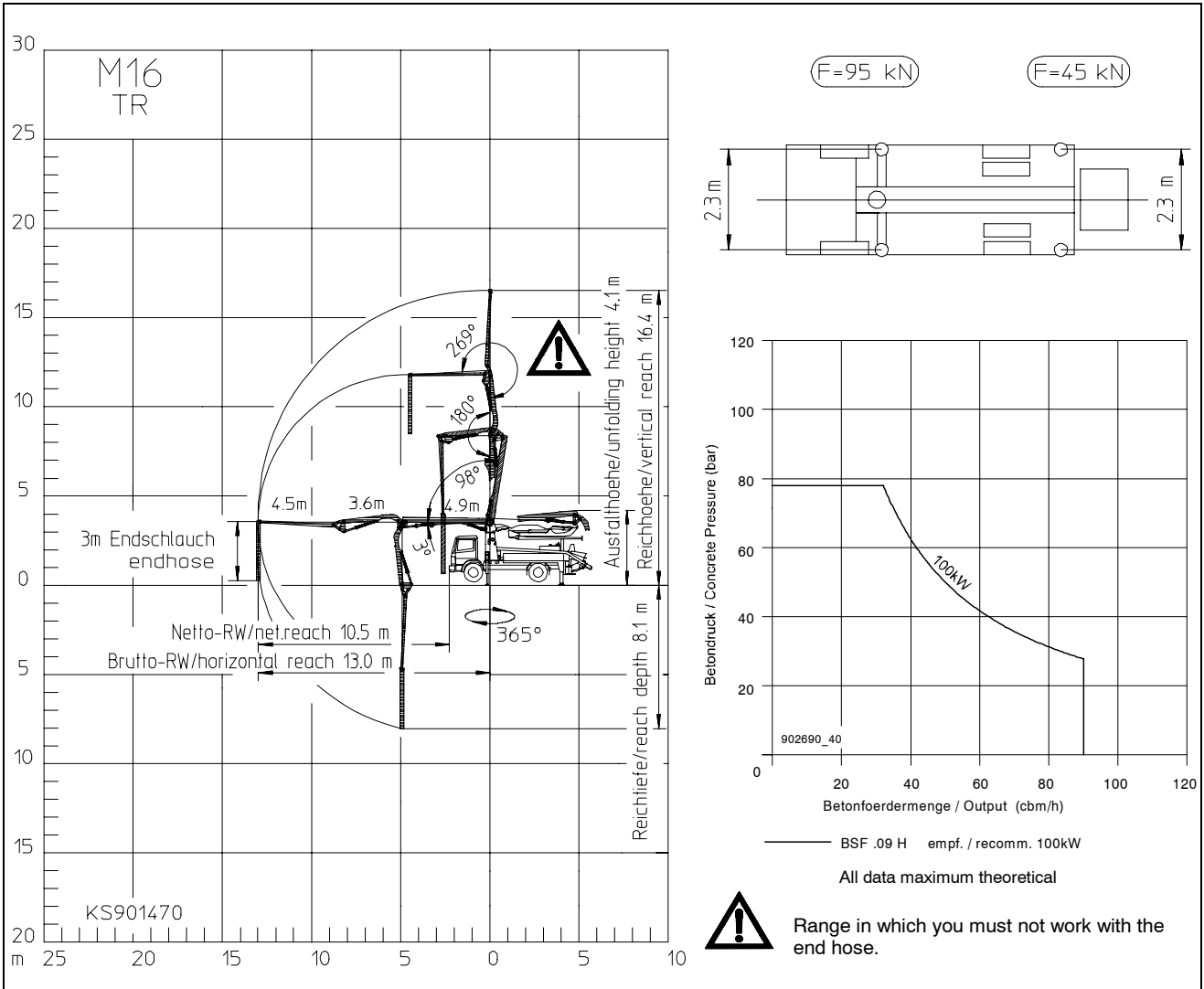

Delivery scope

	Standard	Options Package *	Options Package Plus		Standard	Options Package *	Options Package Plus
support plates 4x in magazine	●			radio remote control prop.incl. CPC with output remote control by regulator, engine start/stop		●	●
concrete line DN 100 4,5", 108x4	●			traffic permission kit		●	●
concrete hopper RS 900 with agitator	●			plash guard foldable on rubber collar		●	●
diagnose interface, central for electric and hydraulic	●			central lubrication hopper, electrical		●	●
remote control b/w with 25 m cable	●			horn at the boom		●	●
central lubrication strip hopper	●			high pressure water pump 100 bar with dry-run protection			●
rubber collar	●			vibrator, electrical			●
painting: arm assembly RAL 3020 signalred	●			hard metal wear parts kit			●
painting: pump MB 1227 chrome yellow	●						
flushing water pump 160 l/min 25 bar	●						
water tank	●						
concrete line DN100 4,5, PM 22		●	●				
EOC (Ergonic output control)		●	●				

* recommended in Europe

Please see quotation for exact serial delivery scope.