

# Truck-mounted concrete pump

## BSF 20.09 H

Output up to 90 m<sup>3</sup>/h  
Delivery pressure up to 78 bar

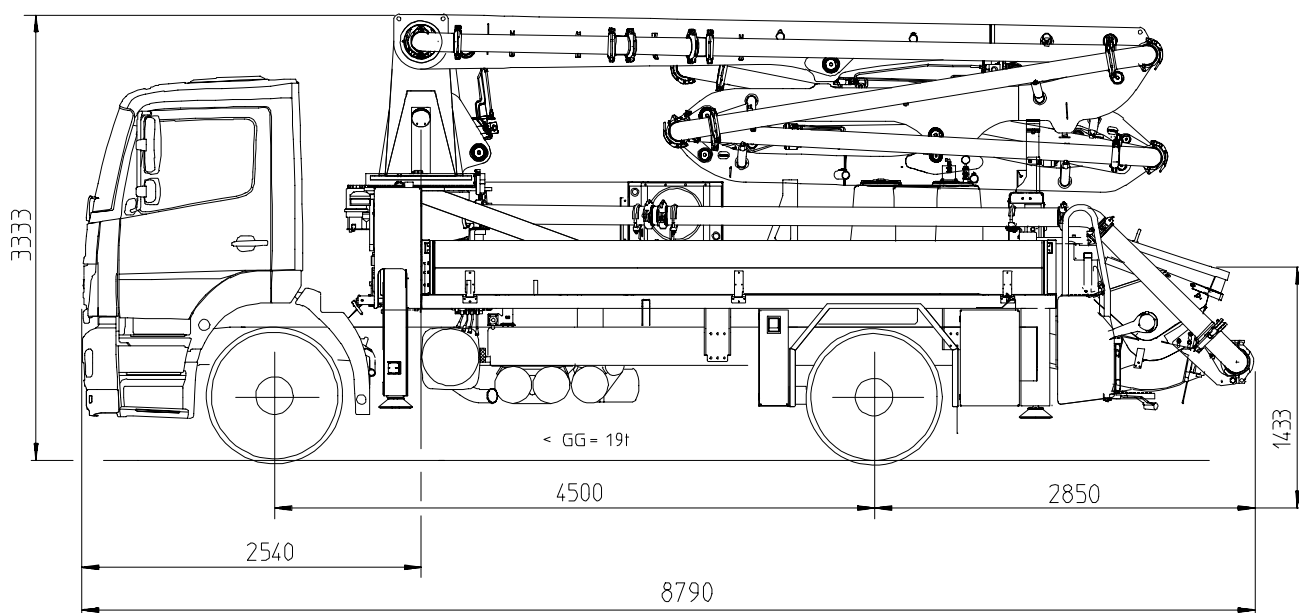
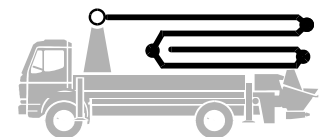

Note: Standard version. Dimensions and weights depend on truck and pump model.  
Dimensions in mm, MB-Axor 1828 as example

### Technical Data

Boom M 20		
Reach height	m	19.5
Horizontal reach	gross	m 16.1
	net	m 13.8
Reach depth max.	m	11.1
Unfolding height	m	3.9
End hose length	m	3
Number of arms	4	
Folding system	ZR-fold (ZR)	
Delivery line	DN 125/5.5	

Pump		BSF	.09 H
Rod side	Output	m <sup>3</sup> /h	-
	Delivery pressure	bar	-
	Strokes	1/min.	-
Piston side	Output	m <sup>3</sup> /h	90
	Delivery pressure	bar	78
	Strokes	1/min.	26
	Delivery cylinder	∅ mm	230
	Stroke	mm	1400

All data maximum theoretical.

## Reach information diagram, Support, Performance diagram

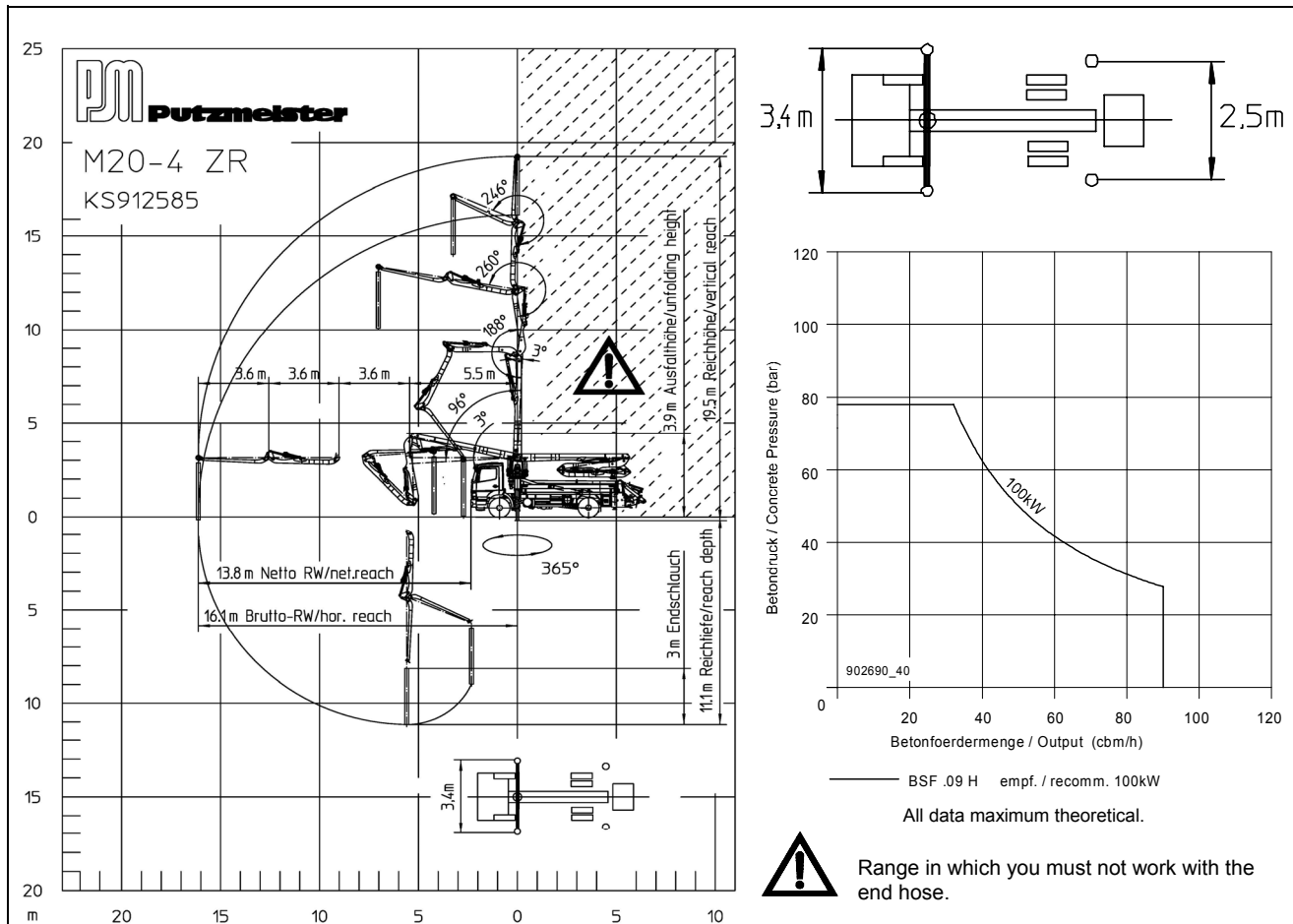

## Delivery scope

	Standard	Options Package *	Options Package Plus		Standard	Options Package *	Options Package Plus
support plates 4x in magazine	●			radio remote control prop.incl. CPC with output remote control by regulator, engine start/stop		●	●
concrete hopper RS 900 with agitator	●			splash guard foldable on rubber collar		●	●
diagnose interface, central for electric and hydraulic	●			central lubrication hopper, electrical		●	●
remote control CPC with 25 m cable with output remote control by regulator, engine start/stop	●			horn at the boom		●	●
central lubrication strip hopper	●			flashlights for 2 support legs front			●
rubber collar	●			lights 2x front side, for illumination support area front			●
painting: arm assembly RAL 3020 signalred	●			high pressure water pump 100 bar with dry-run protection			●
painting: pump MB 1227 chrome yellow	●			vibrator, electrical			●
flushing water pump 160 l/min 25 bar	●			hard metal wear parts kit			●
water tank	●						
concrete line DN125 5,5", 133x4	●						
concrete line DN125 5,5", PM 22 twin layer		●					
concrete line DN125, 5,5" PM 252 Proline			●				
traffic permission kit		●	●				
EOC (Ergonic output control)		●	●				

\* recommended in Europe

Please see quotation for exact serial delivery scope.