

Truck-mounted concrete pump

BSF 31.14 H

Output up to 160 m³/h
Delivery pressure up to 130 bar

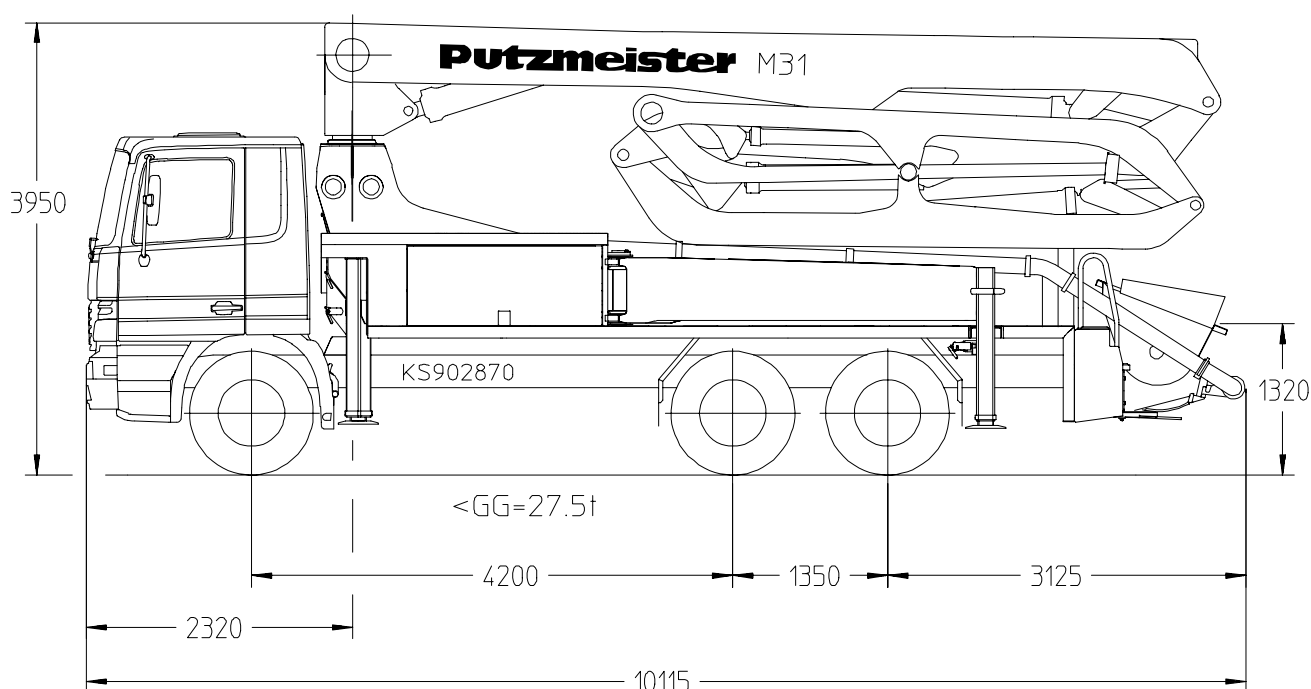

Note: Standard version. Dimensions and weights depend on truck and pump model.
Dimensions in mm, MB-Actros 3332 as example

Technical Data

Boom M 31		
Reach height	m	30.5
Horizontal gross reach	m	26.6
	m	24.3
Reach depth max.	m	20.4
Unfolding height	m	5.7
End hose length	m	4
Number of arms	5	
Folding system	Multi-Z roll-and-fold (MZR)	
Delivery line	DN 125/5.5	

Pump		BSF	.14 H	.16 H	.16 H LS
Rod side	Output	m ³ /h	140	160	-
	Delivery pressure	bar	70	85	-
	Strokes	1/min.	27	31	-
Piston side	Output	m ³ /h	88	108	160
	Delivery pressure	bar	112	130	85
	Strokes	1/min.	17	21	26
Delivery cylinder		∅ mm	230	230	250
Stroke		mm	2100	2100	2100

Delivery line boom max. 85 bar.
All data maximum theoretical.

Reach information diagram, Support, Performance diagram

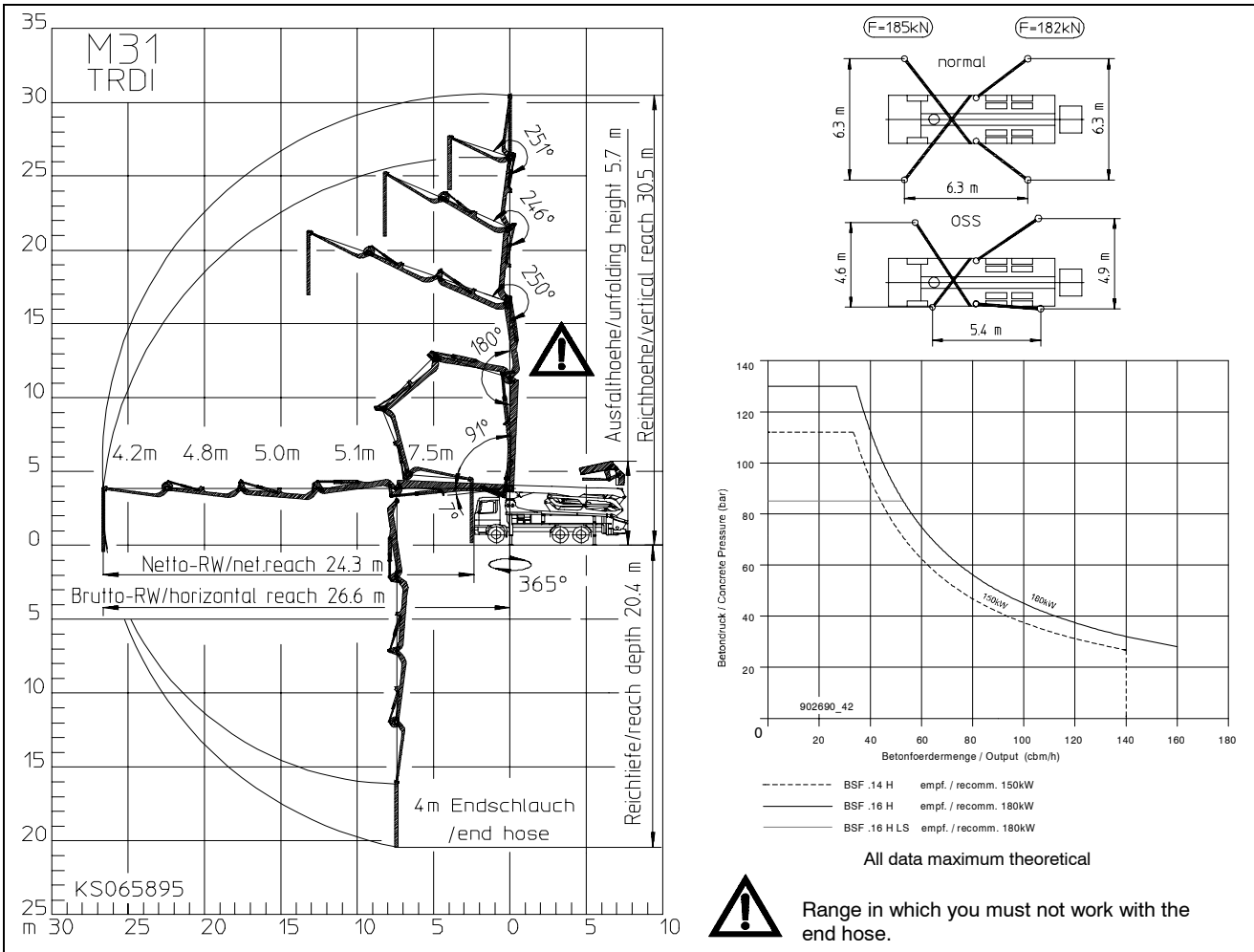

Delivery scope

	Standard	Options Package *	Options Package Plus		Standard	Options Package *	Options Package Plus
support plates 4x in magazine	●			traffic permission kit		●	●
concrete hopper RS 900 with agitator RS 900 M at BSF. 16 H LS	●			EOC (Ergonic output control)		●	●
diagnose interface, central for electric and hydraulic	●			splash guard foldable on rubber collar		●	●
remote control CPC with 40 m cable	●			lighting in toolbox		●	●
central lubrication strip hopper	●			central lubrication hopper, electrical		●	●
rubber collar	●			horn at the boom		●	●
painting: arm assembly RAL 3020 signalred	●			working search light on boom for hopper illumination			●
painting: pump MB 1227 chrome yellow	●			spotlights 4x for illumination support area			●
flushing water pump 160 l/min 25 bar	●			flashlights for 4 support legs front and rear			●
water tank	●			high pressure water pump 100 bar with dry-run protection			●
concrete line DN125, 5.5" 133x4	●			vibrator, electrical			●
concrete line DN125, 5.5" PM 22 twin layer		●		hard metal wear parts kit			●
concrete line DN125, 5.5" PM 252 Proline			●				
support plates 4x + timber wood 8x600 in magazine		●	●				
radio remote control prop.incl. CPC with output remote control by regulator, engine start/stop		●	●				

* recommended in Europe

special: Ergonic Boom Control EBC
One Side Support OSS

Please see quotation for exact serial delivery scope.